

Packaging Description:

SMA parts are shipped in tape and reel. The carrier tape is made from a dissipative (carbon filled) polycarbonate resin. The cover tape is a multiplayer film (Heat Activated Adhesive in nature) primarily composed of polyester film, adhesive layer, sealant and anti-static sprayed agent. The reels are blue in color and made of recyclable plastic.

SMA Packaging Outline

DO-214AC(SMA) Packaging Configuration: Figure 1.0

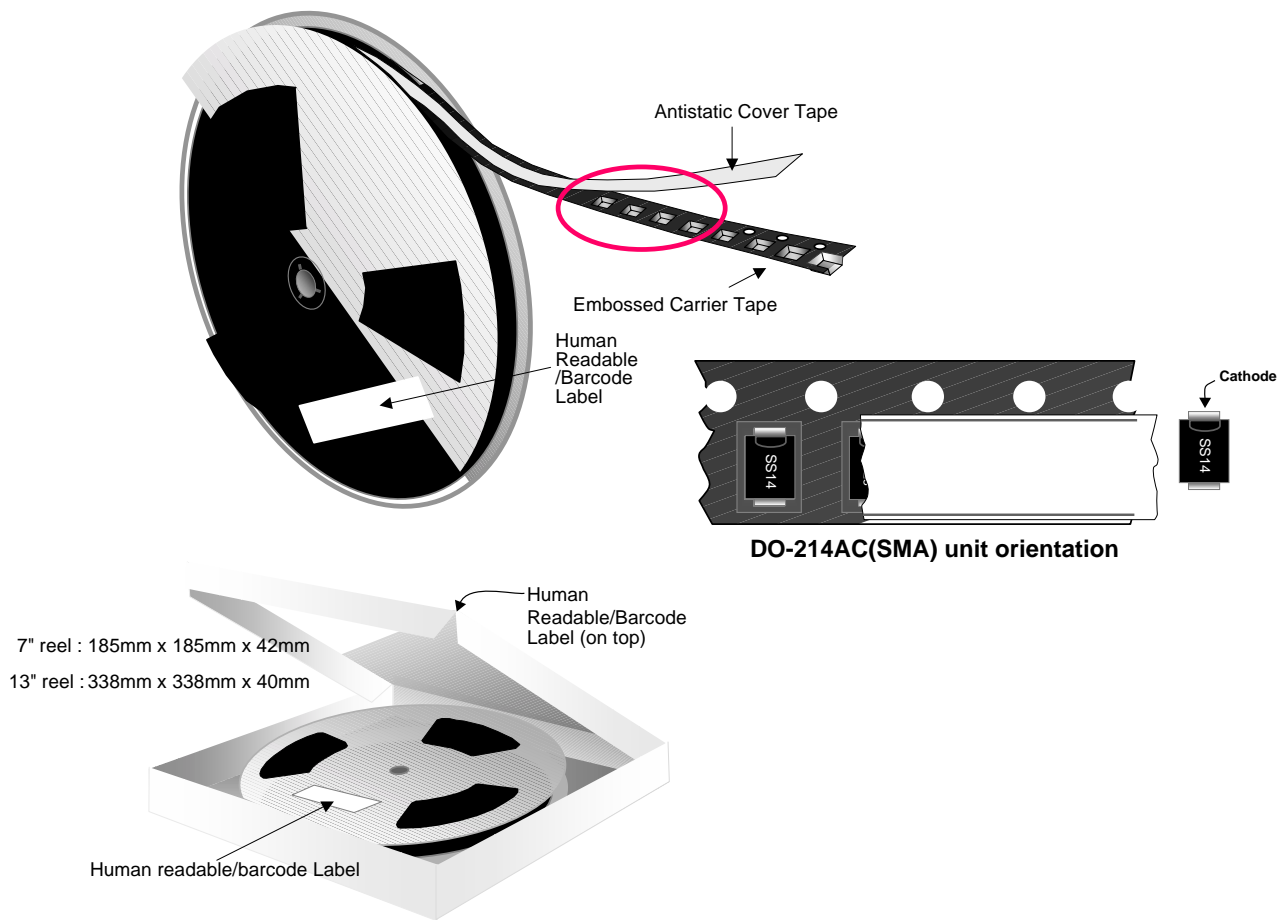

Taping Leader and Trailer

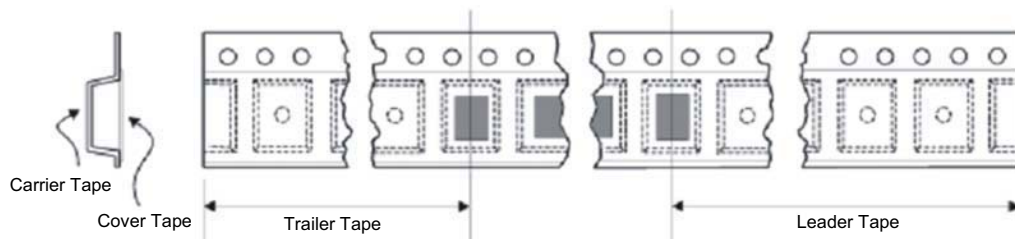

Packaging Reel Outline

Unit: mm

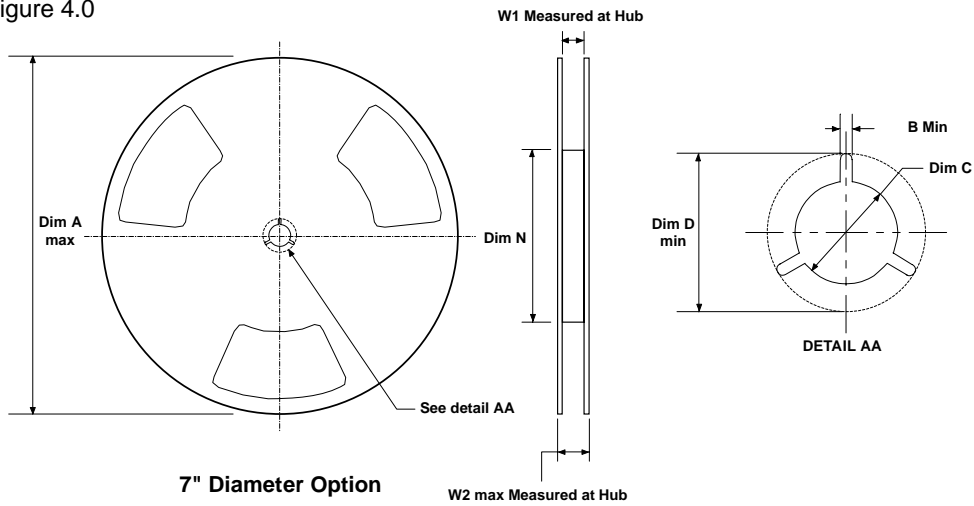
DO-214AC(SMA) Reel Configuration:
 Figure 4.0

Dimensions are in millimeters								
Tape Size	Reel	Dim A	Dim B	Dim C	Dim D	Dim N	Dim W1	Dim W2
12mm	7" Dia	176	3	15	53	N/A	13	17
12mm	13" Dia	330	3	15	74	N/A	13	17

Packaging Quantity:

Reel	Quantity per Reel	Quantity per Box	Minimum Packaging Quantity (MPQ)
7" Dia	2,000 PCS	4,000 PCS	2,000 PCS
13" Dia	5,000 PCS	10,000 PCS	5,000 PCS