

SURFACE MOUNT SCHOTTKY BARRIER RECTIFIER

Reverse Voltage - 20 to 100 Volts Forward Current - 1.0 Ampere

DO-214AC

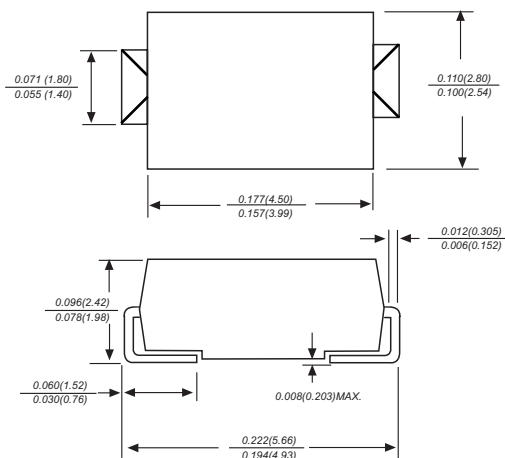

Dimensions in inches and (millimeters)

FEATURES

- ◆ The plastic package carries Underwriters Laboratory Flammability Classification 94V-0
- ◆ For surface mounted applications
- ◆ Metal silicon junction, majority carrier conduction
- ◆ Low power loss, high efficiency
- ◆ Built-in strain relief, ideal for automated placement
- ◆ High forward surge current capability
- ◆ High temperature soldering guaranteed: 250°C/10 seconds at terminals

MECHANICAL DATA

Case: JEDEC DO-214AC molded plastic body
Terminals: leads solderable per MIL-STD-750, Method 2026

Polarity: Color band denotes cathode end

Mounting Position: Any

Weight: 0.003 ounce, 0.093 grams

MAXIMUM RATINGS AND ELECTRICAL CHARACTERISTICS

Ratings at 25°C ambient temperature unless otherwise specified.

Single phase half-wave 60Hz, resistive or inductive load, for capacitive load current derate by 20%.

	SYMBOLS	SS12	SS13	SS14	SS15	SS16	SS18	SS110	UNITS
Maximum repetitive peak reverse voltage	V_{RRM}	20	30	40	50	60	80	100	VOLTS
Maximum RMS voltage	V_{RMS}	14	21	28	35	42	56	70	VOLTS
Maximum DC blocking voltage	V_{DC}	20	30	40	50	60	80	100	VOLTS
Maximum average forward rectified current at T_L (see fig.1)	$I_{(AV)}$	1.0							Amp
Peak forward surge current 8.3ms single half sine-wave superimposed on rated load (JEDEC Method)	I_{FSM}	40.0							Amps
Maximum instantaneous forward voltage at 1.0A	V_F	0.55		0.70		0.85		Volts	
Maximum DC reverse current at rated DC blocking voltage $T_A=25^\circ\text{C}$ $T_A=100^\circ\text{C}$	I_R	0.5							mA
		10.0			5.0				
Typical junction capacitance (NOTE 1)	C_J	110			90			pF	
Typical thermal resistance (NOTE 2)	$R_{\theta JA}$	88.0							$^\circ\text{C}/\text{W}$
Operating junction temperature range	T_J	-65 to +125					-65 to +150		$^\circ\text{C}$
Storage temperature range	T_{STG}	-65 to +150							$^\circ\text{C}$

Note: 1. Measured at 1MHz and applied reverse voltage of 4.0V D.C.

2. P.C.B. mounted with 0.2x0.2" (5.0x5.0mm) copper pad areas

RATINGS AND CHARACTERISTIC CURVES SS12 THRU SS110

AVERAGE FORWARD RECTIFIED CURRENT, AMPERES

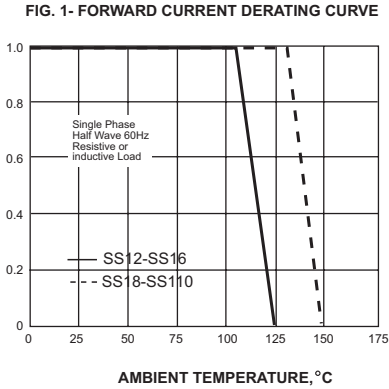

PEAK FORWARD SURGE CURRENT, AMPERES

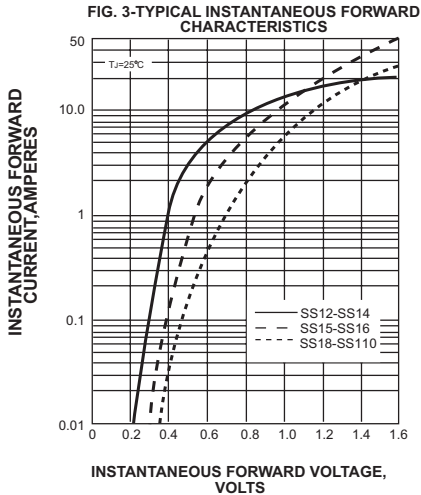
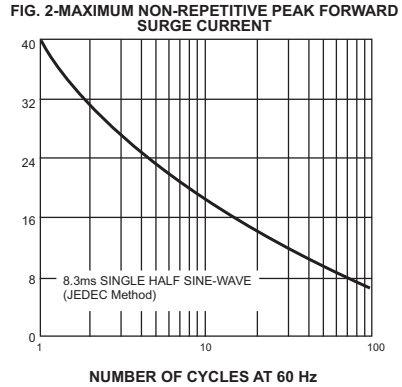

INSTANTANEOUS REVERSE CURRENT, MILLIAMPERES

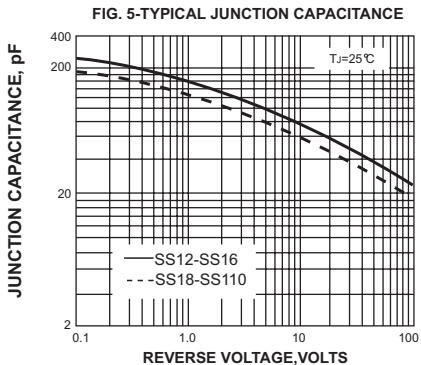
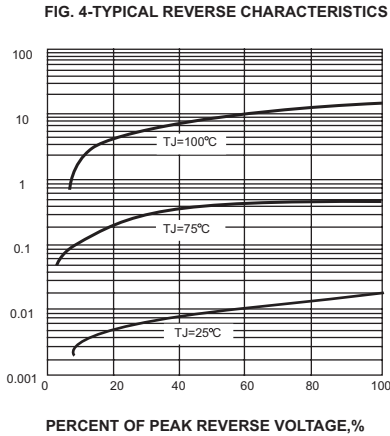

TRANSIENT THERMAL IMPEDANCE, °C/W

